

User Manual



Laser Level

 **RGK** **PR-81**

Caution

The RGK PR-81 laser plane builder uses a potentially dangerous laser source. Do not direct the laser beam into your eyes, as this may result in injury.

With prolonged contact with the eyes, the laser can damage eyesight, even from a long distance. Do not direct the laser beam at people or animals.

Observe the rules of care and operation, do not disassemble, repair, or modify the device yourself - this may lead to the device failure.

Batteries can leak and damage the instrument. Observe the following rules:

- Observe the polarity.
- Do not short-circuit the battery compartment.
- Do not recharge conventional batteries.
- Do not mix old and new batteries, or batteries from different manufacturers.
- Do not leave batteries inside the device if it is not used for a long time.
- Do not give batteries to children and animals.
- Do not dispose of batteries in fire.
- Do not dispose of batteries with household waste. Dispose of them according to local regulations.

Laser level RGK PR-81 projects visible laser planes. This allows to perform various tasks in construction and repair, including leveling, construction of vertical and horizontal planes. The device can be used both indoors and outdoors. The presence of a pulse mode of operation of the device allows the detector to be used to increase the operating range even in conditions of low visibility of the laser beam (bright sun, etc.).

Device composition

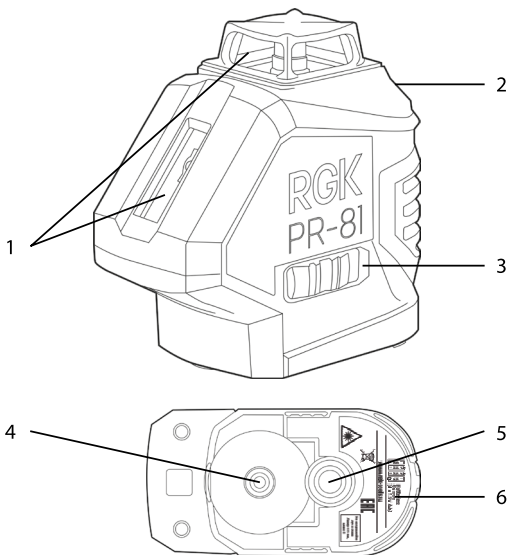

1. Laser emitter windows
2. Control panel
3. Pendulum lock switch
4. 1/4" tripod socket
5. 5/8" tripod socket
6. Battery compartment cover

Getting started

Before starting work, place the level on a work surface or fasten it to a tripod, pole, or wall mount. The device can operate in two main modes:

1. Pendulum lock: switch on the left

This line laser is a precision instrument that must be handled with care. When not in use, the pendulum must always be in position .

Locking the pendulum allows the instrument to better withstand vibration and prevent possible damage during transport or as a result of a fall.



2. Automatic alignment: switch on the right

When the pendulum is unlocked , the instrument can be leveled automatically. The tilt of the instrument body must not exceed 4° for the auto-leveling function to work.



Control panel functions

Laser selection

Pressing the line selection button allows you to select different options for the relative position of the lines in the sequence below:

- when the device is switched on, all the beams light up;
- a single press only turns on the horizontal plane;
- pressing twice only turns on the vertical plane;
- pressing the device three times returns it to its original position.

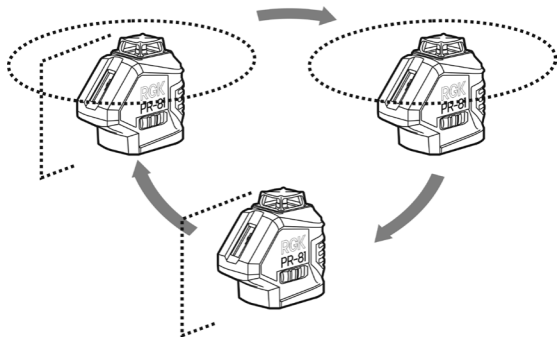

Control panel

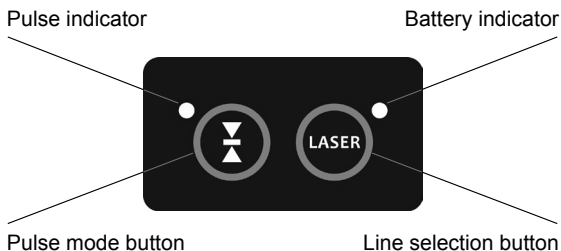

Additional functions

Compensator lock

With the instrument pendulum locked (switch on the left side), press and hold the line select button for 3 seconds to activate the compensator lock mode. The device emits laser beams in this mode, but the accuracy is not adjusted, because the pendulum is locked. This operating mode of the device is used to draw lines and planes with arbitrary angles of inclination.

Compensator Lockout Mode Activated Signal: The laser beam will flash every 5 seconds to remind you that the laser auto-align is off.

Signaling

Horizontal deviation signal

If the pendulum is not locked and the angle of inclination of the level does not exceed 4° , the instrument is in automatic leveling mode. In this case, the LED indicators are off. If the base of the instrument is tilted more than 4° , the laser beam will blink.

Low battery alarm

The red low battery indicator LED turns on and starts flashing slowly if the operating voltage drops below 4.4V. In such a situation, replace the batteries.

Checking the Accuracy of the Laser Level

Plane tilt

1. Install the device in the center of a room about 5 meters long.
2. Switch on the device.
3. Mark a point at the center of the laser cross.
4. Turn the instrument 180° .
5. Mark the second point.
6. Place the appliance at a distance of 0.5 m from the wall and reapply the marks.

If the differences a_1-a_2 and b_1-b_2 do not exceed the accuracy of the device specified in its characteristics, the accuracy of the device is within acceptable limits.

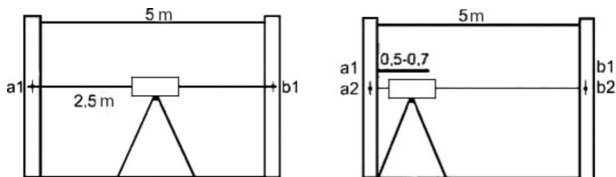

Plane curve

1. Install the appliance at a distance of about 5 m from the wall.
2. Mark a point at the center of the laser cross.
3. Turn the instrument so that the point is shifted about 2.5 m to the side and make sure that the deviation of the horizontal line from the mark does not exceed the accuracy specified in the specifications of the instrument.

Vertical check

A plumb line is used to check the vertical of the device. Set up the level about 1.5 m from the plumb line.

1. Unlock the compensator, turn on the vertical laser head, align the axis of the vertical laser line with the lower point of the plumb line.
2. Make sure that the deviation of the vertical line axis from the gimbal does not exceed 0.2 mm per 1 m of the gimbal length (example: for a plumb line with a length of 2.5 m, the deviation should not be more than 0.5 mm)

If the accuracy of the device does not correspond to the specified in the specifications, contact the service center.Б13.

Specifications

Accuracy	±0,2 mm/1 m
Auto-leveling	±4°
Operating range without receiver	20 m
Range of operation with the receiver	80 m
Tripod thread	1/4", 5/8"
Laser type	635 nm, class II
Usage temperature range	-10 °C to 50 °C
Dimensions	119 × 62 × 115 mm
Power supply	4 AA batteries x 1.5V
Continuous operation time on one set of batteries (all lasers on)	about 10 hours
Dust and moisture protection	IP54

Device advantages

- Because of the pulse mode, the device can work both indoors and outdoors.
- The horizontal plane extends over the entire area of the room by 360°.
- The vertical plane reaches the ceiling.
- No need to disassemble the instrument for calibration.
- A built-in locking system allows the expansion joint to be disabled during transport to avoid damaging vibration.
- The ribbed surface of the device body allows you to hold it securely in your hands.
- Two 1/4" and 5/8" threaded sockets on the underside of the housing allow the level to be mounted on fixing devices of different designs.

Caring for the device

Your level is a precision measuring instrument, handle it with care. After each use, clean the level of dust with a soft cloth, dampening it with water if necessary. Always wipe the appliance dry. Do not store the device in wet or humid conditions. When transporting, block the compensator by setting the switch to position . This will prevent damage to the mechanism and failure of the device.

Possible causes of incorrect measurement results

- Taking measurements through glass or plastic windows;
- Dirty laser window;
- Mechanical impact on the device. Check the accuracy of the instrument if it has been knocked or dropped;
- Significant fluctuations in ambient temperatures. If it is necessary to use the instrument in a cold place after storage in a warm place (or vice versa), please wait a few minutes before taking measurements to allow the temperature to equalize.

Electromagnetic compatibility (EMC)

There is a possibility of:

- interference with other technical devices (e.g., navigation equipment) by this device;
- interference with the operation of this device by other technical devices (for example, strong radiation of electromagnetic waves near industrial plants or radio transmitters).

EAC

www.rgk-tools.com